

YR. _____ EXHIBITORS LAY-OUT DIAGRAM

SPBGMA

BLUEGRASS MUSIC AWARDS NATIONAL CONVENTION

Sheraton Music City Hotel - Nashville, TN

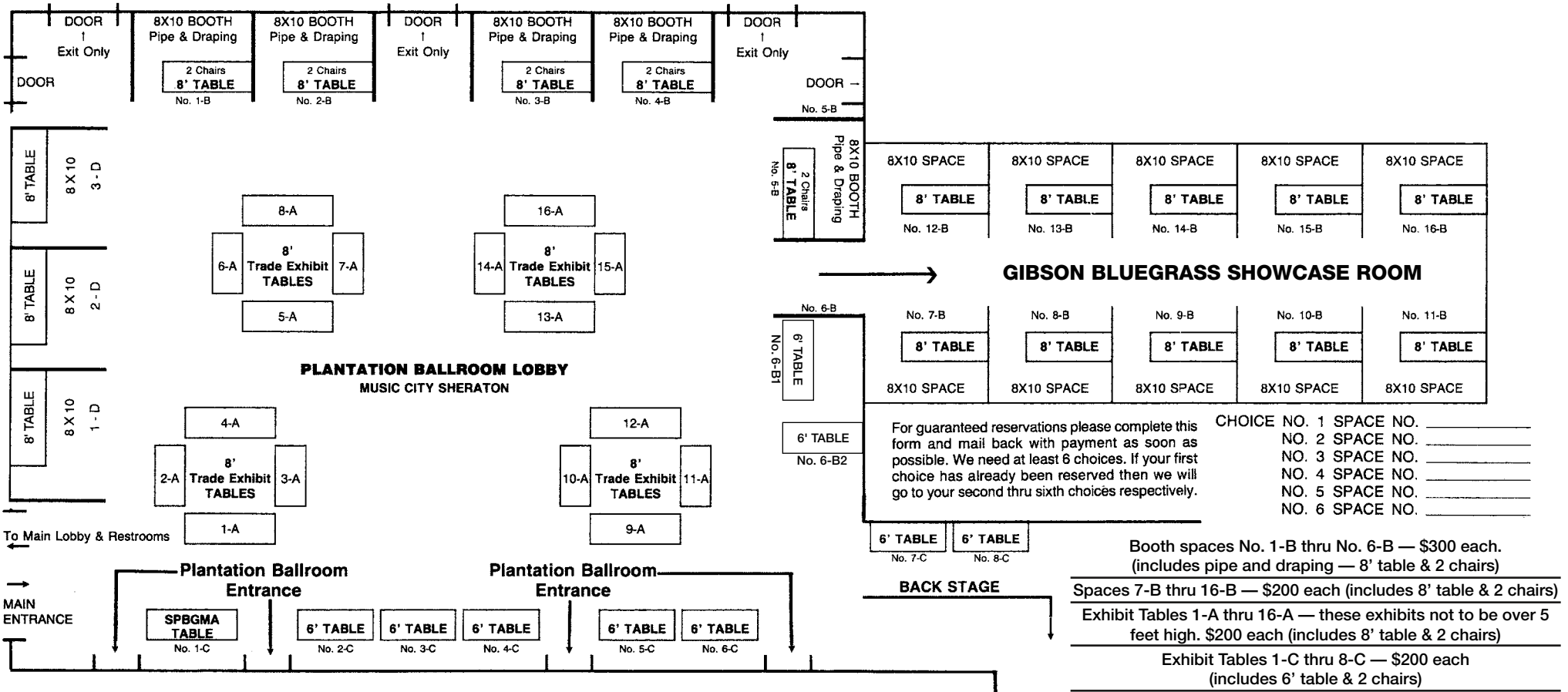

For guaranteed reservations please complete this form and mail back with payment as soon as possible. We need at least 6 choices. If your first choice has already been reserved then we will go to your second thru sixth choices respectively.

CHOICE NO. 1 SPACE NO. _____
 NO. 2 SPACE NO. _____
 NO. 3 SPACE NO. _____
 NO. 4 SPACE NO. _____
 NO. 5 SPACE NO. _____
 NO. 6 SPACE NO. _____

Booth spaces No. 1-B thru No. 6-B — \$300 each.
 (includes pipe and draping — 8' table & 2 chairs)

Spaces 7-B thru 16-B — \$200 each (includes 8' table & 2 chairs)

Exhibit Tables 1-A thru 16-A — these exhibits not to be over 5 feet high. \$200 each (includes 8' table & 2 chairs)

Exhibit Tables 1-C thru 8-C — \$200 each (includes 6' table & 2 chairs)

The above exhibit space fees reserves your space for the entire weekend and includes two 3 day concert tickets.

Company Name: _____
 Contact Person Name: _____ Phone: () _____
 Address: _____
 Street City State Zip

DO NOT FILL OUT THIS SQUARE - Confirmation Only

Your _____ Choice has been reserved and confirmed.

Sign: _____